

# SERVICE MANUAL



VER 1.0



ISSUE DATE: Jun. 10, 2011



IMPORTANT

- ▶ Please read the manual carefully and keep it in mind before using this machine.
- ▶ Put this manual within touch of your reference in anytime.

# PRECAUTIONS FOR USE

The following safety precautions are given throughout this manual. They must be strictly followed to protect those who install, use or maintain this product as well as to protect players, visitors and property.

For safety reasons.

- The following suggestions should be adhered to:

## WARNING

Disregarding could result in serious injury.

## CAUTION

Disregarding could result in injury or product damage.

- The following graphic suggestions describe the types of precautions to be followed.



Indicates a care should be taken.



Forbidden.



Indicates a matter which must be performed.

- Precautions to be followed:

**Certain procedures require a qualified in-shop maintenance person or industry specialist. For such instructions, a qualified person must take care of the jobs.**

- Otherwise an electric shock, machine trouble, or a serious accident may result.
- Replacing the machine parts, inspecting and maintaining the machines, and troubleshooting must be assigned only to a qualified in-shop maintenance person or industry specialist. This booklet gives instructions that hazardous jobs in particular must be handled by an industry specialist. Qualified in-shop maintenance person and industry specialist are defined as follows.

### **Qualified in-shop maintenance person**

- A service staff shall have experience in operations of game machines. The staff shall be responsible for assembly, installation, inspection and maintenance of the machine.

### **Industry specialist**

- An industry specialist must be engaged in designing, manufacturing, inspecting and servicing amusement machines. He or she must have an education in electrical, electronic and mechanical engineering, and routinely maintain and repair amusement machines.

# PRECAUTIONS FOR USE

## ⚠ WARNING

Be sure to consult an industry specialist when setting up, moving or transporting this product.

- This product should not be set up, moved or transported by any one other than an industry specialist.
- When installing this product, set the 4 leg levelers evenly on the floor and make sure that the product is installed stably in a horizontal position. Unstable installation may result in injury or accident.
- When installing this product, do not apply undue force on movable parts. Otherwise, injury and accident may result, or the product may be damaged.

The machine for indoor usage only does not install outside.

Do not set the game machine up near emergency exits.

Protect the game machine from:

- Rain or moisture.
- Direct sunlight.
- Direct heat from air-conditioning and heating equipment, etc..
- Hazardous flammable substances.
- Otherwise an accident or malfunction may result.

Do not place containers holding chemicals or water on or near the game machine.

Do not place objects near the ventilating holes.

Do not bend the power cord by force or place heavy objects on it.

Never plug or unplug the power cord with wet hands.

Never unplug the game machine by pulling the power cord.

## ⚠ CAUTION

Be sure to use indoor wiring within the specified voltage requirements. For extension cord, use the specified rating or more.

Be sure to use the attached power cord.

Never plug more than one cord at a time into the electrical receptacle.

Do not lay the power cord where people walk through.

Be sure to ground this product.

Do not exert excessive force when moving the machine.

For proper ventilation, keep the game machine 100mm(4") away from the walls.

Do not alter the system related dipswitch settings.

**⚠ WARNING**

If there is any abnormality such as smoke, bad smell or abnormal noise being emitted from the machine, immediately turn OFF the main power switch and unplug the power cord from the receptacle to stop operating it.

- Using the machine in abnormal conditions could result in fire or accidents.

In case of abnormality

1. Turn OFF the main power switch.
2. Unplug the power cord from the receptacle.
3. Contact your nearest dealer.

**Do not leave the power cord plugged in improperly or covered with dust.**

- Doing so could result the power cord periodically.

**⚠ CAUTION**

**Do not use this product anywhere other than industrial areas.**

- Using in a residential area or an area next to a residential area could affect signal reception of radios, television sets, telephones, etc..
- Do not give shock the surface of glass products.

- Please do not play this game if
  - When you do drinking;
  - When your physical condition is not normal;
  - When you are in pregnancy;
  - When you have on a pulse controller;
  - When you have recently experienced a cramp or fainting away while watching TV.
- Avoid excessive force/shock while playing/moving the game.
- While do games, pay attention to surrounding.

**Do not plug or unplug the power cord with wet hands.**

**In handling the power cord, follow the instructions below.**

- |   |  |
|---|--|
| • Do not damage the power cord.           | • Do not modify the power cord.            |
| • Do not bend the power cord excessively. | • Do not twist the power cord.             |
| • Do not heat the power cord.             | • Do not pull the power cord.              |
| • Do not bind the power cord.             | • Do not stand on the power cord.          |
| • Do not sandwich the power cord.         | • Do not drive a nail into the power cord. |

**If the power cord or power plug becomes damaged, stop using the machine immediately and ask your nearest dealer to replace the parts.**

# PRECAUTIONS FOR USE

## ⚠ WARNING

Be sure to turn OFF the main power switch and unplug the power cord from the receptacle before inspecting or cleaning the machine. 

When replacing parts, be sure to use parts of the correct specifications. Never use parts other than the specified ones. 

Opening inside the machine shall be done by machine specialist only as high electric current is being sent inside. For game machine with monitor, a care should be taken while opening its back door. If not, a damage to the inside parts or the monitor may occur. 

If the sub power switch of the service panel is turned OFF without turning OFF the main power switch of the power supply unit, some parts in the units remain live. When opening the back door, be sure to turn OFF the main power switch and unplug the power cord from the receptacle. 

Strictly refrain from disassembly and repair of parts which are not indicated in this manual, as well as settings and remodeling. 

To clean the game machine, wipe it with a soft cloth dampened in a neutral detergent.

- Using thinner or other organic solvent or alcohol may decompose the material.
- Electrical shock or equipment failure could be caused by water entering the inside of the machine.

## ⚠ CAUTION

Components in the game are sensitive to vibrations and impact. Care should be used when moving and transporting the game machine. 

Be sure not to let the machine tip over.

Before moving the machine, be sure to turn OFF the main power switch, unplug the power cord from the receptacle and remove the power cord from the machine. 

Before moving take the machine, off the levelers and move it on the casters.

Avoid excessive force while moving the machine.

.....

## PRECAUTIONS IN HANDLING

- When setting up, inspecting, maintaining, moving or transporting this product, follow the procedures and instructions set forth in this manual and perform such work safely.
- Do not set up, handle, inspect, maintain, move or transport this product under conditions equivalent to the condition of "WARNING" or "CAUTION" specified in this manual.
- If a new owner is to have this product as a result of transfer, etc., be sure to give this manual to the new

# CONTENT

## **1. DIMENSION & SPECIFICATION**

1-1. DIMENSION

1-2. SPECIFICATION

1-3. NAME OF PARTS & STICKER LOCATION

[ COMPONENTS ]

## **2. INSTALLATION**

## **3. PRODUCT CHARACTER**

## **4. SET UP**

## **5. TROUBLESHOOTING**

5-1. SETTING FND DISPLAY

5-2. FRONT FND DISPLAY

5-3. BILLBOARD LED

5-4. FLUORESCENT LAMP

5-5. WAVE LAMP

5-6. IN CASE OF POWER FAILURE

5-7. SENSOR ERROR

5-8. IN CASE OF MALFUNCTION OF GAME PANEL

5-9. COIN SELECTOR OPERATING

5-10. TICKET DISPENSER OPERATING

5-11. BUTTON & COUNTER

5-12. SOUND ERROR

## **6. REPLACEMENT OF CONSUMABLES**

6-1. REPLACEMENT OF MOTOR

6-2. REPLACEMENT OF SENSOR

6-3. REPLACEMENT OF MAIN BOARD

6-4. REPLACEMENT OF PCB

6-5. REPLACEMENT OF LAMP

## **7. PARTS LIST**

7-1. ASSEMBLY

7-2. LIST

7-3. PICTURE

## **8. WIRING DIAGRAM**

# 1. DIMENSION & SPECIFICATION

## 1-1. DIMENSION

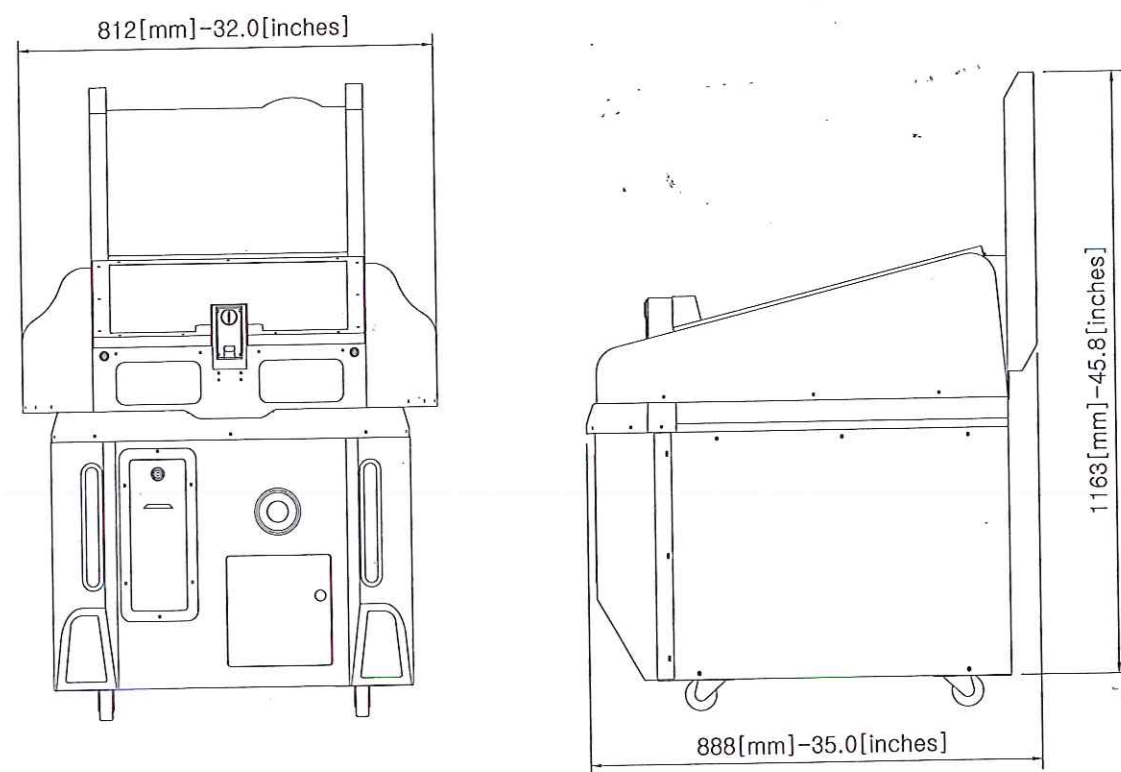

## 1-2. SPECIFICATION





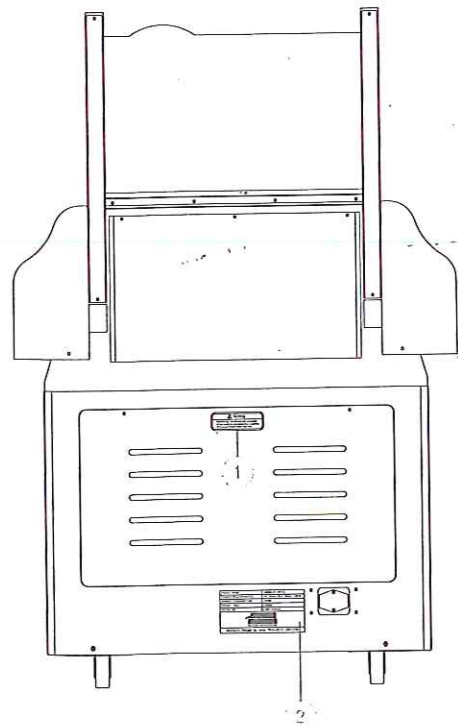
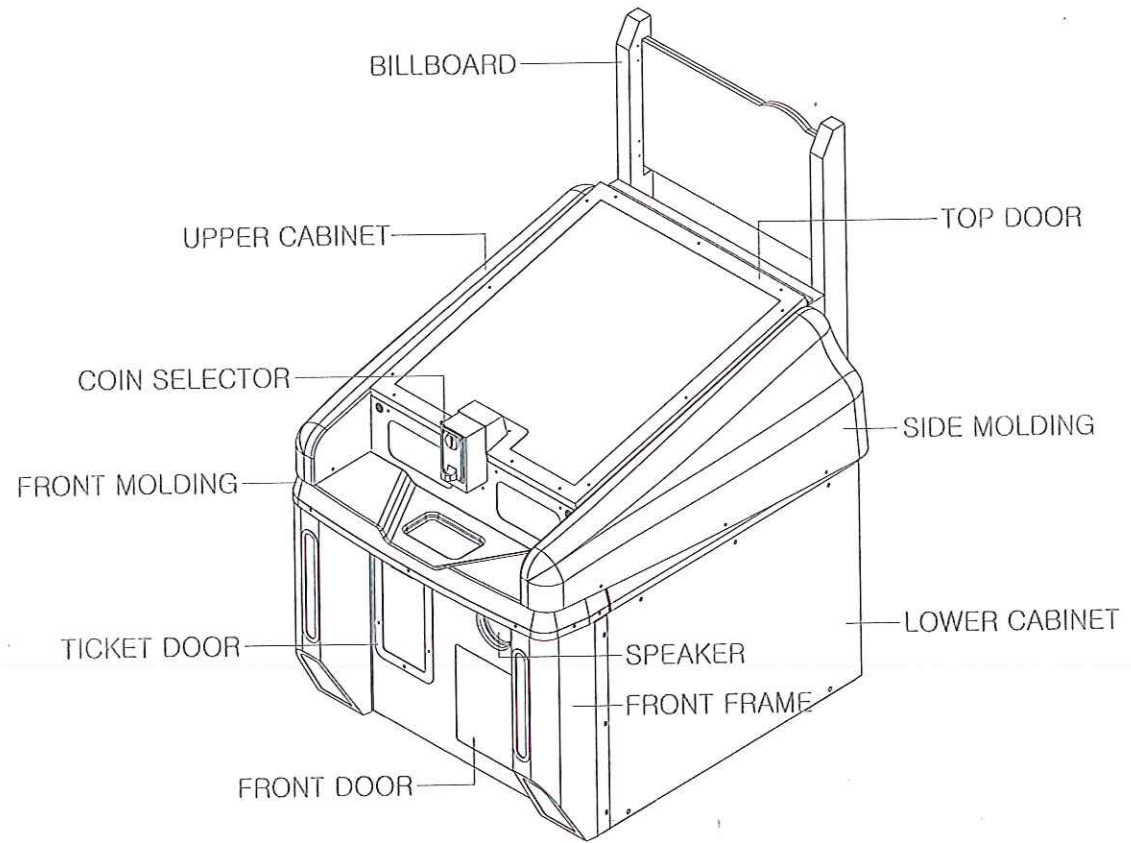



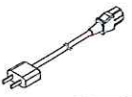

DIMENSION (W x D x H)	812 x 888 x 1163 (mm)
WEIGHT (kg)	168 kg
VOLTAGE	AC 110V
FREQUENCY RANGE	50 Hz ~ 60 Hz
CONSUMPTION	200.W

### 1-3. NAME OF PARTS & STICKER LOCATION



1	2										
<p><b>Warning</b>          *Assembling, Installation and Servicing          of the game be performed by a qualified          and an authorized personnel only*</p>	<table border="1"> <tr> <td>MODEL NAME</td> <td>WINNERS TOGGLE</td> </tr> <tr> <td>POWER REQUIREMENTS</td> <td>AC 220V 50/60Hz</td> </tr> <tr> <td>POWER CONSUMPTION</td> <td>200W</td> </tr> <tr> <td>WEIGHT (KG)</td> <td>165kg</td> </tr> <tr> <td>MODEL NO.</td> <td>GWIT0000001</td> </tr> </table> <p style="text-align: center;"><b>ANDAMIRO</b>          XXXXXXX-XXXXXXXXXXXX</p> <p style="text-align: center;">Koyang-si, Kyonggi-do, Korea Phone 82-31-903-2114</p>	MODEL NAME	WINNERS TOGGLE	POWER REQUIREMENTS	AC 220V 50/60Hz	POWER CONSUMPTION	200W	WEIGHT (KG)	165kg	MODEL NO.	GWIT0000001
MODEL NAME	WINNERS TOGGLE										
POWER REQUIREMENTS	AC 220V 50/60Hz										
POWER CONSUMPTION	200W										
WEIGHT (KG)	165kg										
MODEL NO.	GWIT0000001										

# COMPONENTS

NO.	PART NAME	SPEC.		QTY
1	WRENCH	3mm		1
2	AC POWER CORD	110V		1
3	PUSH KEY	8001		2
4	TARGET	1.5mm PINK		2
5	TARGET	10mm PINK		2
6	TARGET	15mm PINK		2
7	TARGET	20mm PINK		2
8	TARGET	25mm PINK		2
9	TARGET	35mm PINK		2
10	BOLT	M6x20L		4
11	MANUAL			1

## 2. INSTALLATION

- Need to have installation place.  
Maintenance Zone & Play zone should have at least 150mm x 500mm each.

### (IMPORTANT)

- Please do not install the equipment in the place where it is exposure to direct sunlight in order to avoid malfunction of sensor. Indoor intensity of illumination need to be 200lux~300Lux.

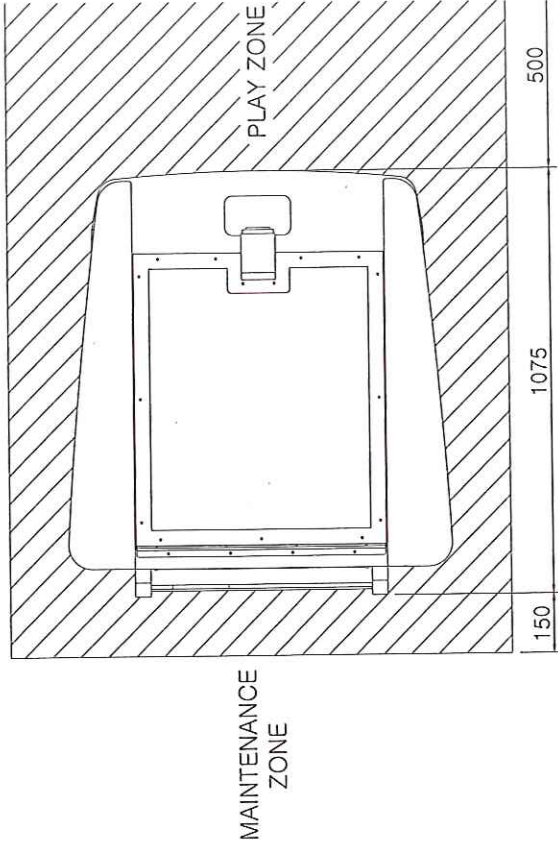

### [ How to installation ]

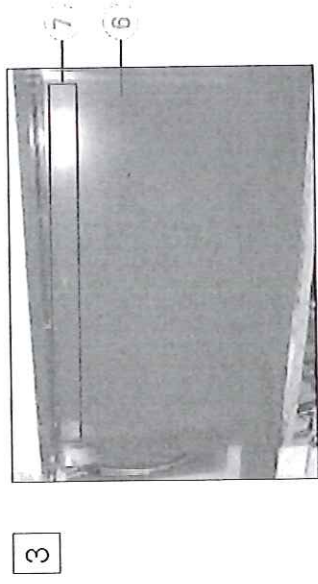
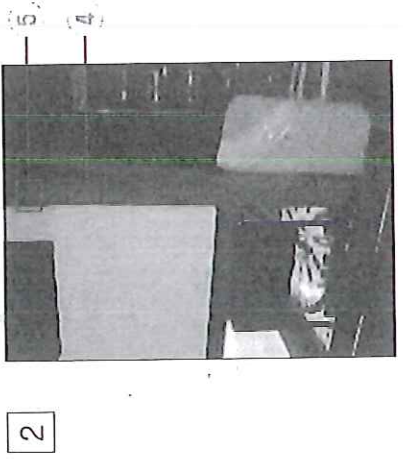
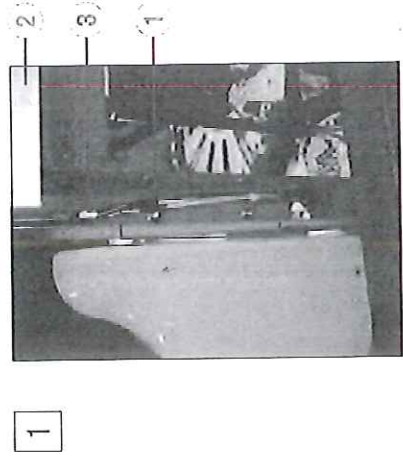

- 1) Assemble (1) M6 bolt (4spots) on the body temporarily,
- 2) and fix it tightly after installation of (2) Billboard
- 3) After connection connector (3)
- 4) assemble (4) "Billboard Fixing frame cover" (5)
- 5) Using (7) M4 bolt (3spots), assemble (6) Upper rear door.

### 3. PRODUCT CHARACTER

- Refreshing Single player, quick coin & ticket redemption game!
- Accumulating bonus jackpot for continuous play.
- Simple game of Skill : Suitable for all ages.
- Player watch their coins drop the chute onto revolving playfield.
- Targets around the edge have different amount of tickets.
- Continuous Game play ability yields consistent income.
- Operator friendly & Effortless maintenance.

### 4. SETUP

#### 4-1. SETUP METHOD

##### (1) Composition

- 1 You may find SW1, SW2, SW3 in the control panel when you open front door of cabinet.

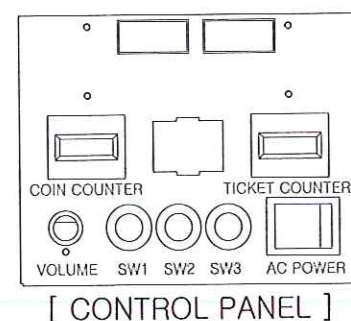

[ it is set that the payout of ticket is 22~25ticket per coin. ]

- The Explanation of SETUP MODE & CLEAR MODE are as following

- 1 You may access SETUP MODE by pressing SW1.
- 2 SETUP mode have menu mode for choosing and Setting mode for setting a value.
- 3 In menu-mode, Menu items is blinking, by pressing SW1 it's returned to Game.

By Pressing SW2, it change Menu mode or move digit when it's more two digit number.

By pressing SW3, it set a value

SETTING MODE	CONTENT
	Initial number of Bonus ( 000 ~ 500 )
	Maximum number of Bonus ( 099 ~ 999 )
	The amount of bonus growth ( 0 ~ 9 )
	Target #1 ( clockwise from the left in each section) ( 000 ~ 199 )
	Target #2 ( 000 ~ 199 )
	Target #3 ( 000 ~ 199 )
	Target #5 ( 000 ~ 199 )
	Target #6 ( 000 ~ 199 )
	Target #7 ( 000 ~ 199 )
	Mercy(free) ticket (0~9) per credit ( 0~9 )
	Wheel Speed ( 0 ~ 9 )
	Demo Sound ON/OFF ( on / off )

\* SOUND TEST : you can perform sound test if you press SW2 in Set up menu mode.

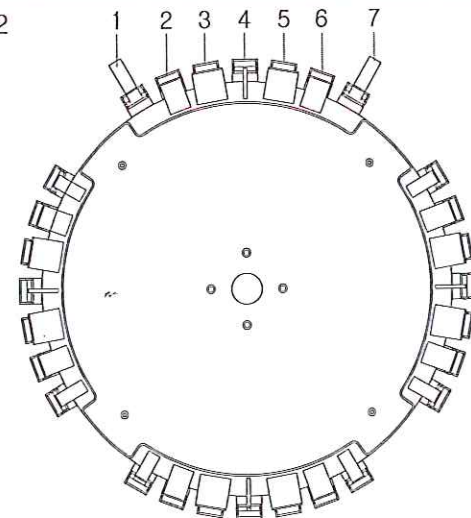

### 4-3. CLEAR MODE

- 1 Go to CLEAR MODE by turning on machine whiling pushing SW1.
- 2 Menu item is shown on Bonus FND in CLEAR MODE, and the related number of each Menu it is shown on SETUP FND.
- 3 Push SW2 for Menu item movement.  
Push SW3 to delete or initialize number of each Menu item.

CLEAR MODE		CONTENT
BONUS FND	SETUP FND	
		Initialize Bonus number
		Delete the remained or dispensing ticket
		Set all the numbers to FACTORY setting numbers
		Return to Game mode

### 4-4. ERROR MODE

ERROR MODE	CONTENT	
WHEEL ENCODER ERROR		When the wheel does not turn for a certain period of time, the machine stops working and display the error number at FND of Jackpot bonus.
TICKET ERROR		Win tickets are not dispensed for a certain period of time, the machine stops working and display the error number at FND of Jackpot bonus.

## 4-5. TEST MODE

- 1 The machine moves to the TEST MODE when the machine turns on while pushing SW3 button.
- 2 "---0" is shown on Bonus FND when the machine moves to TEST MODE.

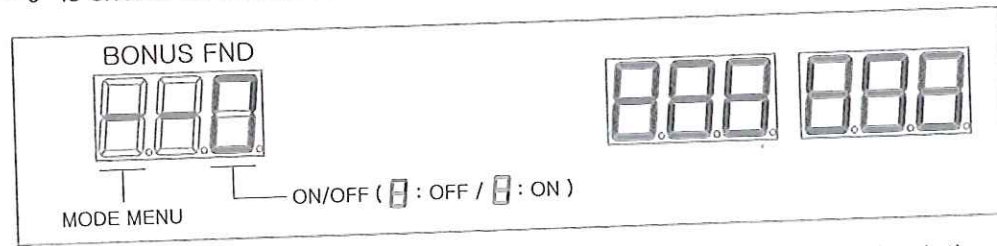



- 3 Move to the next menu by pushing SW1 button. Push SW3 button to check the each content.

TEST MODE	CONTENT
BONUS FND	
	INITIAL STAGE
	TICKET DISPENSOR MOTOR OFF
	TICKET DISPENSOR MOTOR ON
	TICKET EMPTY LAMP OFF
	TICKET EMPTY LAMP ON
	COIN COUNTER OFF
	COIN COUNTER ON
	TICKET COUNTER OFF
	TICKET COUNTER ON
	MAIN MOTOR OFF
	MAIN MOTOR ON

## 4-6. SENSOR & SWITCH TEST

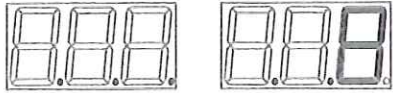
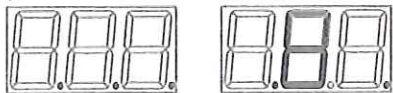
1 When a sensor or switch is checked, following numbers are shown on FND.

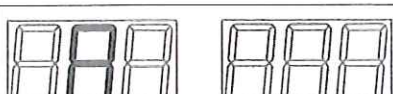
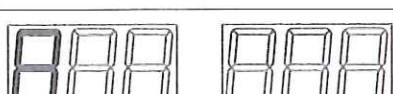
TEST MODE	CONTENT
SETUP FND	
	COIN CHECK FOR A-COIN INSERTED INTO COIN SELECTOR
	SENSOR CHECK OF OUTSIDE WHEEL ENCODER
	SENSOR CHECK OF INSIDE WHEEL ENCODER
	SENSOR CHECK OF TARGET SUCCESS
	SENSOR CHECK OF TICKET DISPENSOR
	SWITCH CHECK FOR TICKET EMPTY BUTTON

# 5. TROUBLESHOOTING

## 5-1. SETTING FND DISPLAY

\* COMMON : INPUT VOLTAGE CHECK  
WIRING CONNECTION CHECK

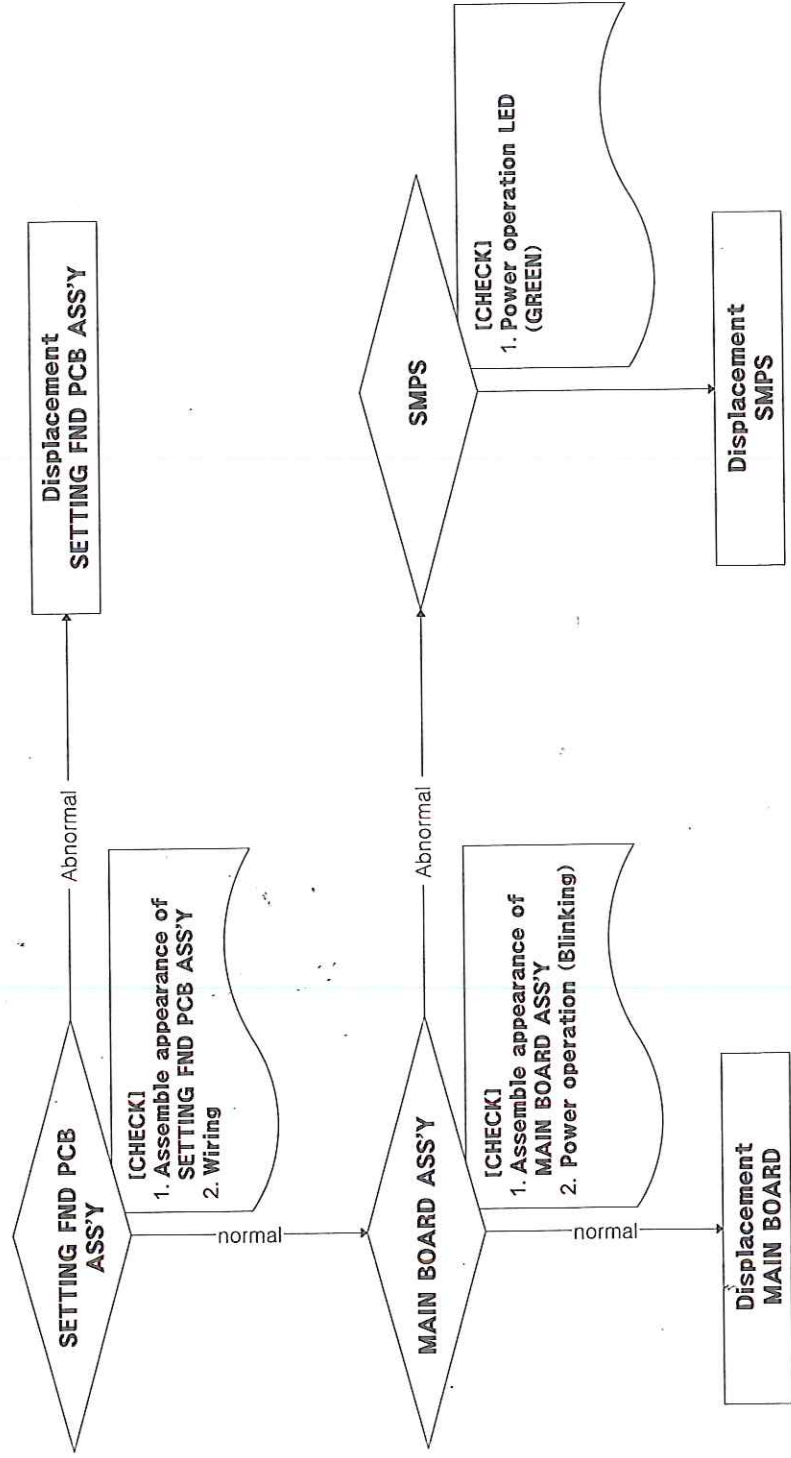

## 5-2. FRONT FND DISPLAY

\* COMMON : INPUT VOLTAGE CHECK  
WIRING CONNECTION CHECK

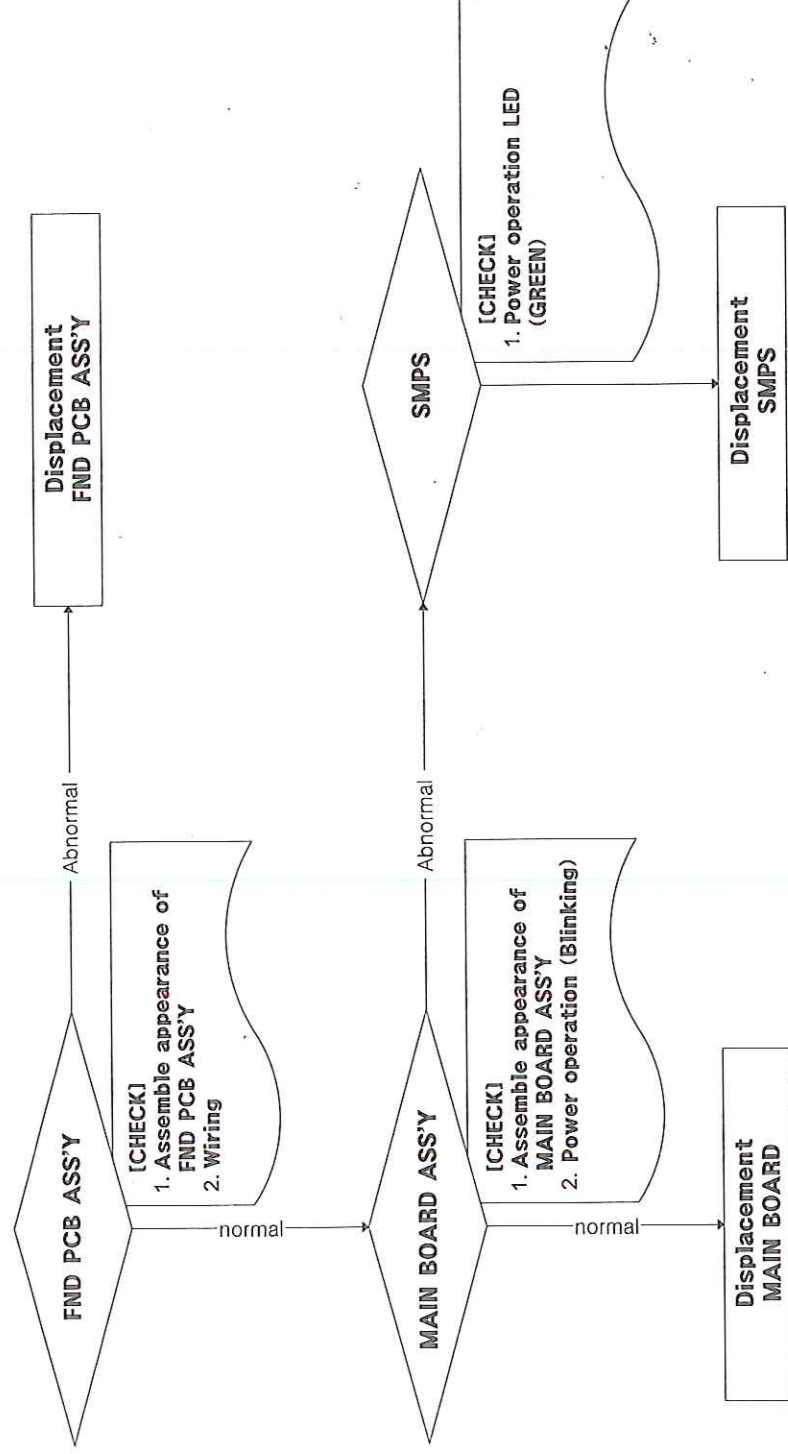

# 5-3. BILLBOARD LED

\* COMMON : INPUT VOLTAGE CHECK  
WIRING CONNECTION CHECK

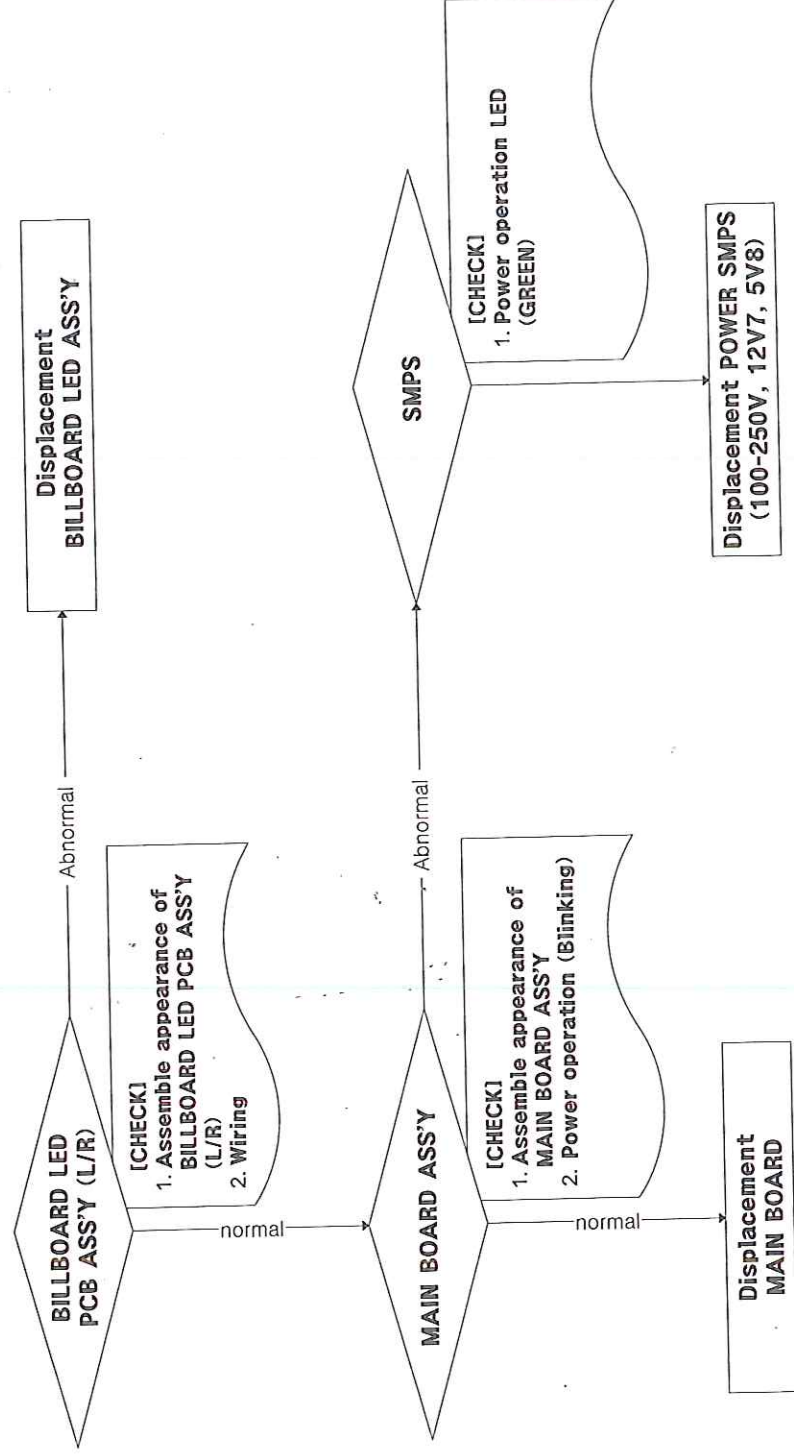

### 5-4. FLUORESCENT LAMP

\* COMMON : INPUT VOLTAGE CHECK  
WIRING CONNECTION CHECK

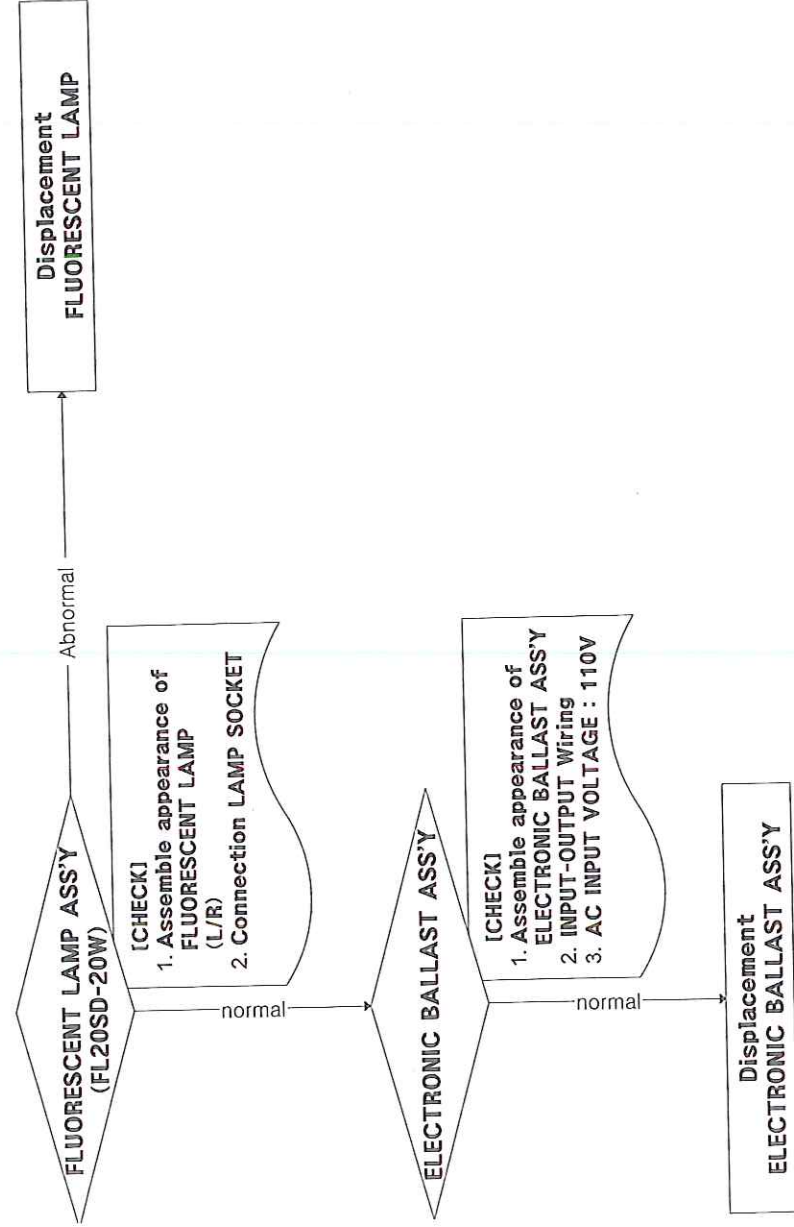

### 5-5. 3 WAVE LAMP

\* COMMON : INPUT VOLTAGE CHECK  
WIRING CONNECTION CHECK

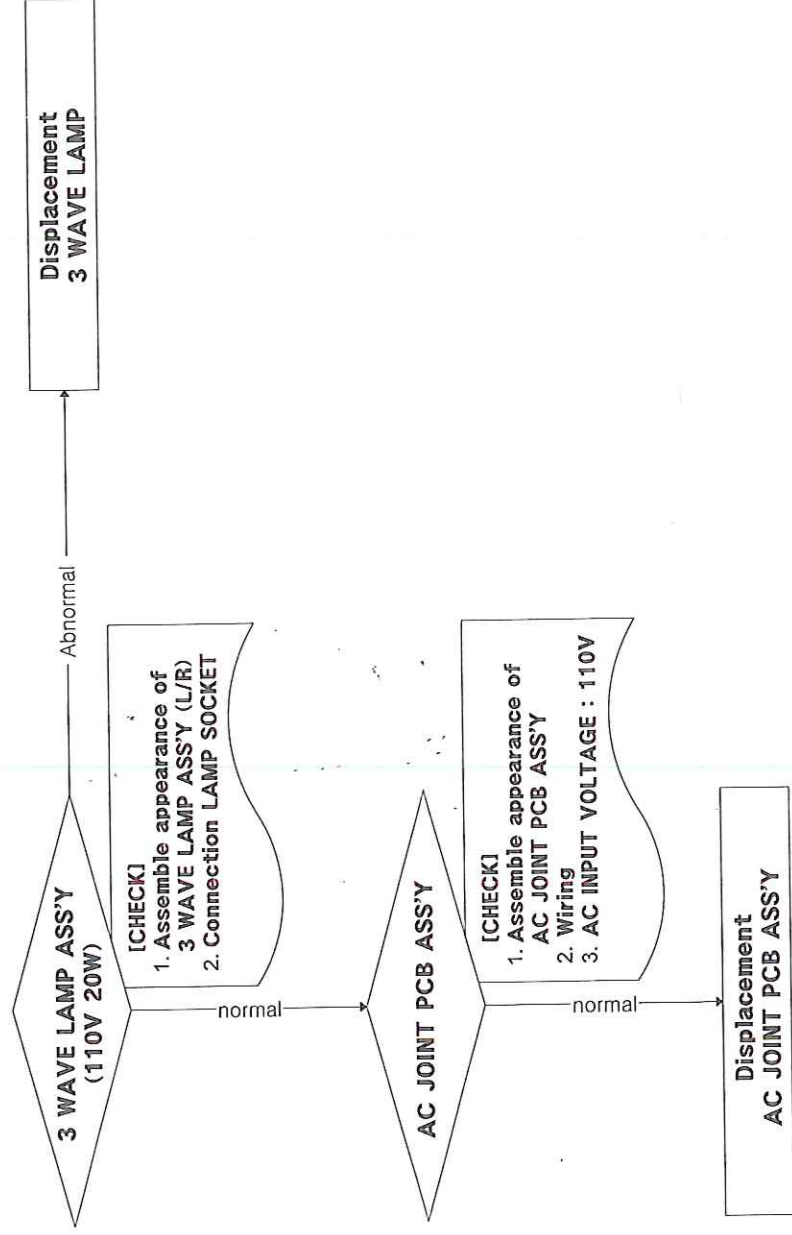

### 5-6. IN CASE OF POWER FAILURE

\* COMMON : INPUT VOLTAGE CHECK  
WIRING CONNECTION CHECK

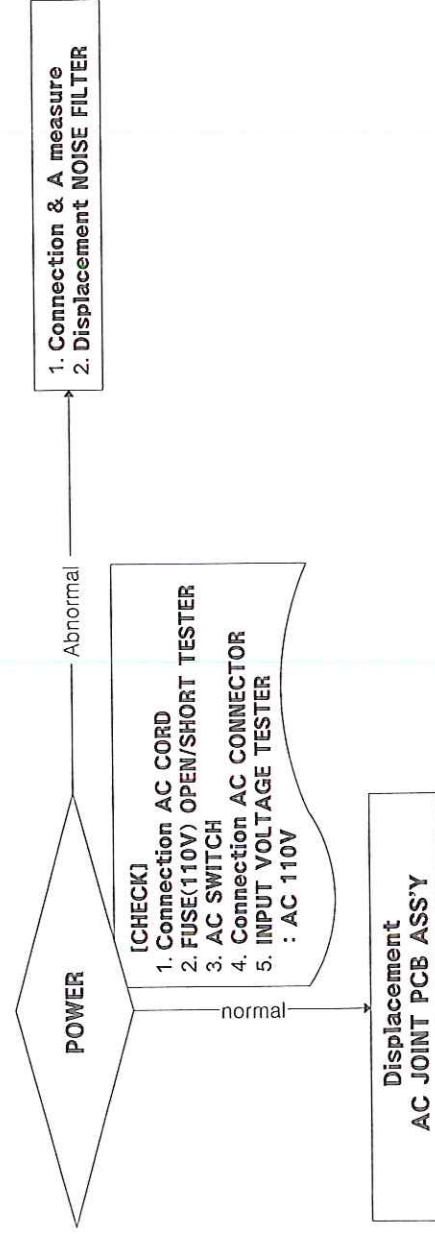

### 5-7. SENSOR ERROR

\* COMMON : INPUT VOLTAGE CHECK  
WIRING CONNECTION CHECK

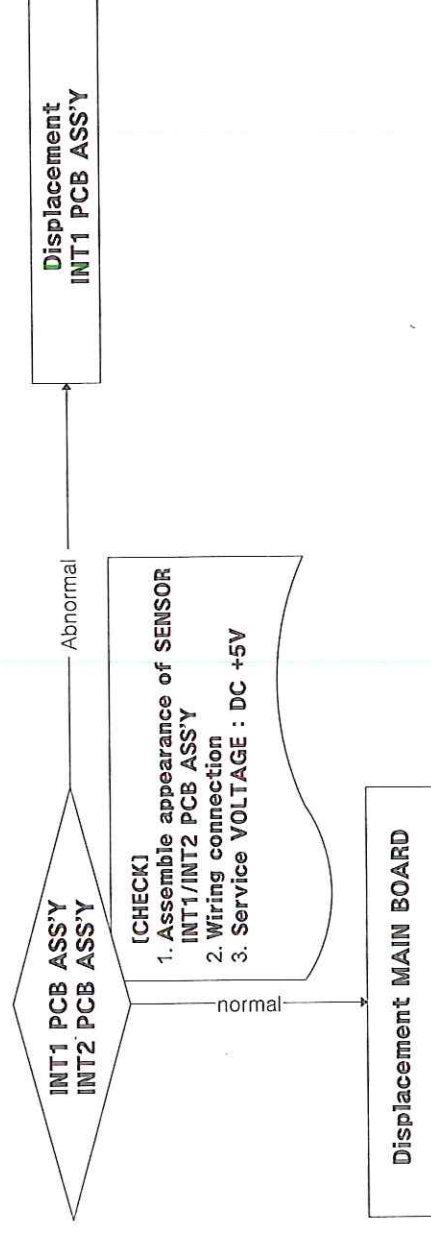

### 5-8. IN CASE OF MALFUNCTION OF GAME PANEL

\* COMMON : INPUT VOLTAGE CHECK  
WIRING CONNECTION CHECK

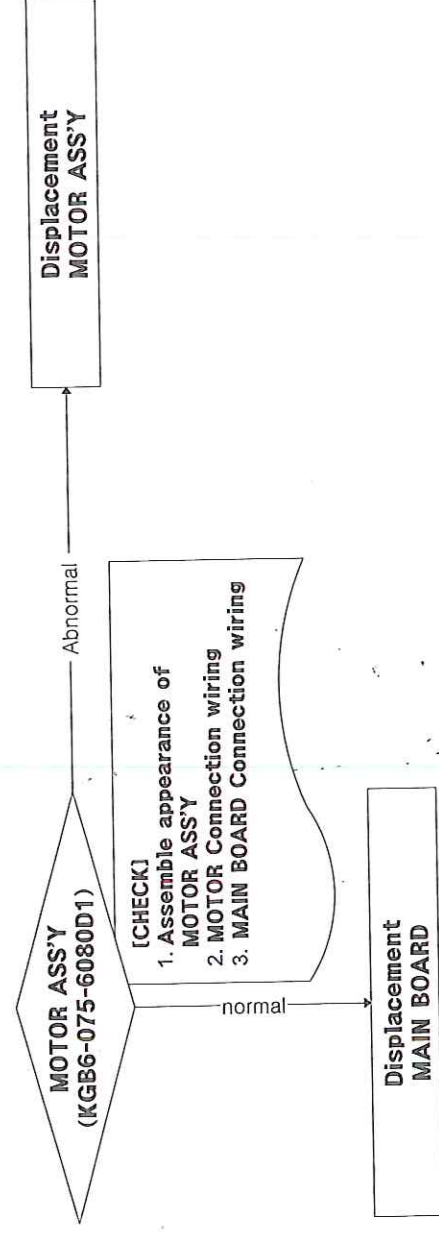

### 5-9. COIN SELECTOR OPERATING

\* COMMON : INPUT VOLTAGE CHECK  
WIRING CONNECTION CHECK

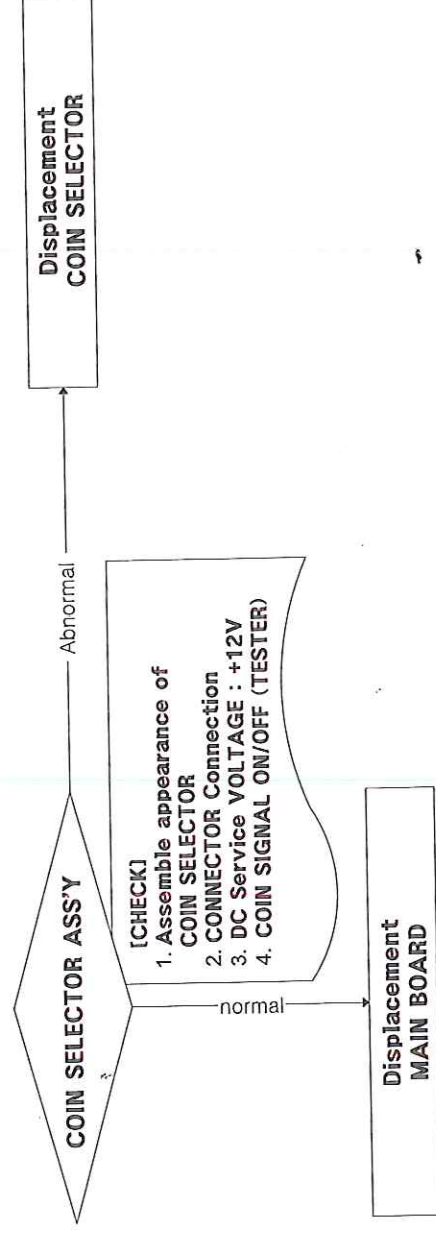

## 5-10. TICKET DISPENSER OPERATING

\* COMMON : INPUT VOLTAGE CHECK  
WIRING CONNECTION CHECK

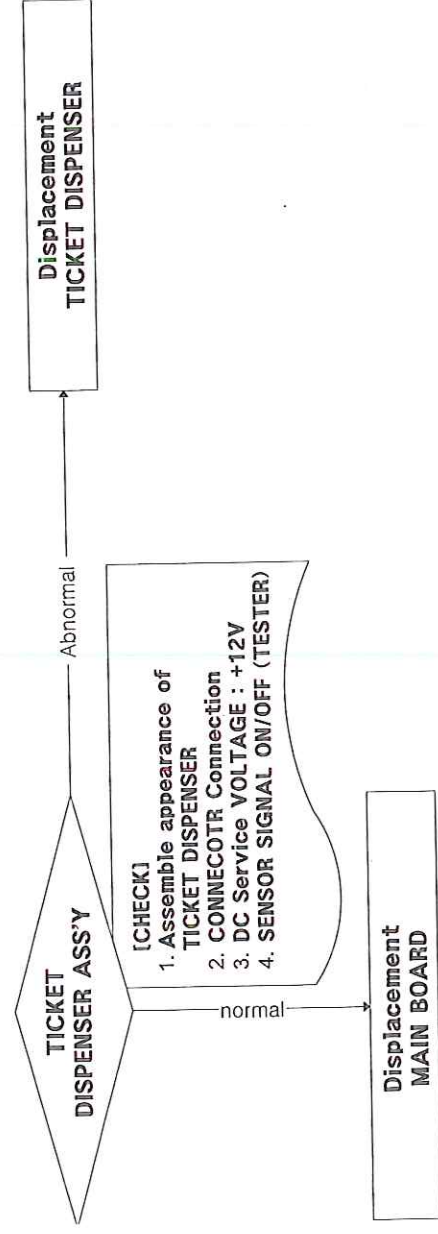

# 5-11. BUTTON & COUNTER

\* COMMON : INPUT VOLTAGE CHECK  
WIRING CONNECTION CHECK

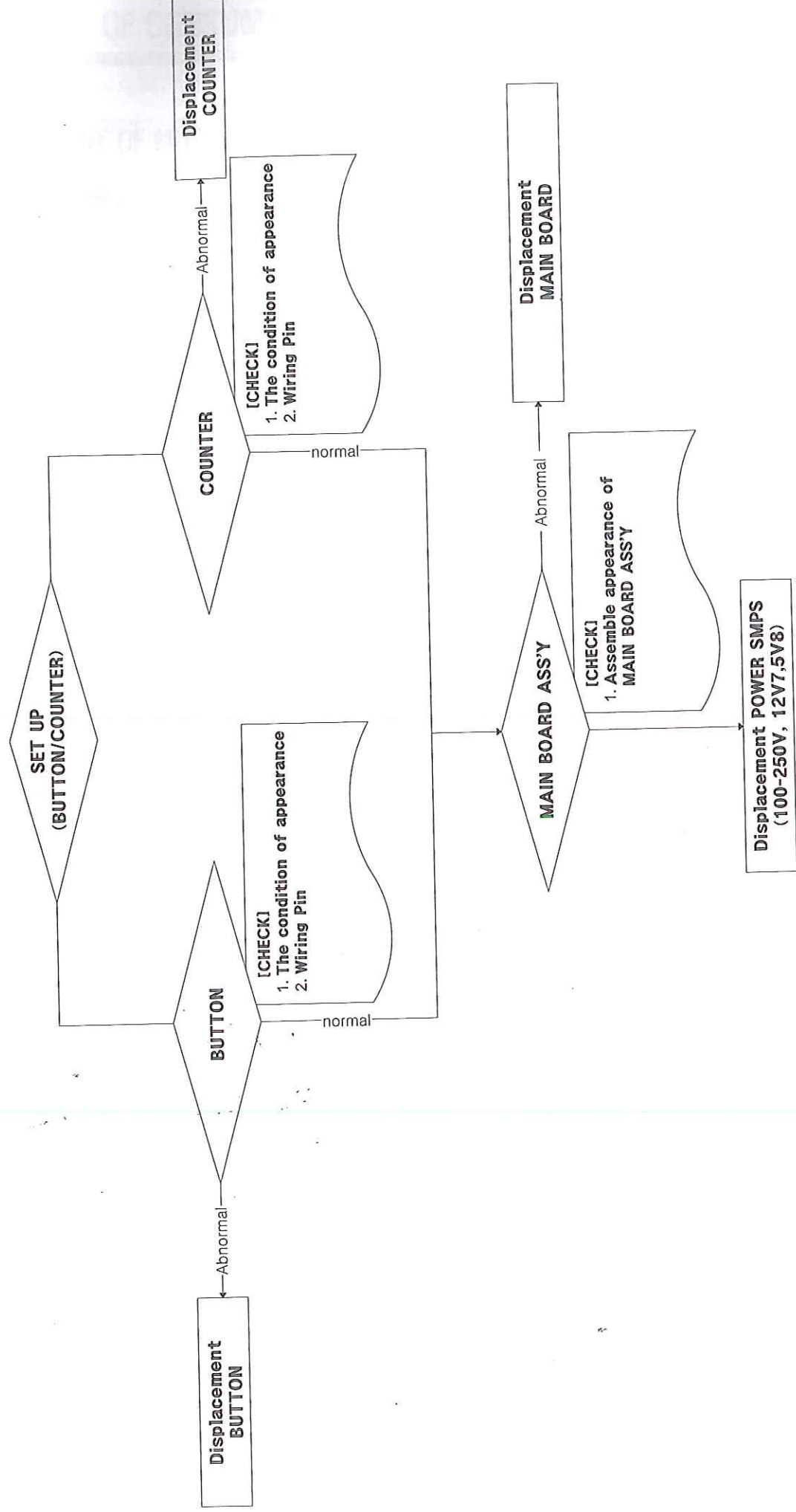

### 5-12. SOUND ERROR

\* COMMON : INPUT VOLTAGE CHECK  
WIRING CONNECTION CHECK

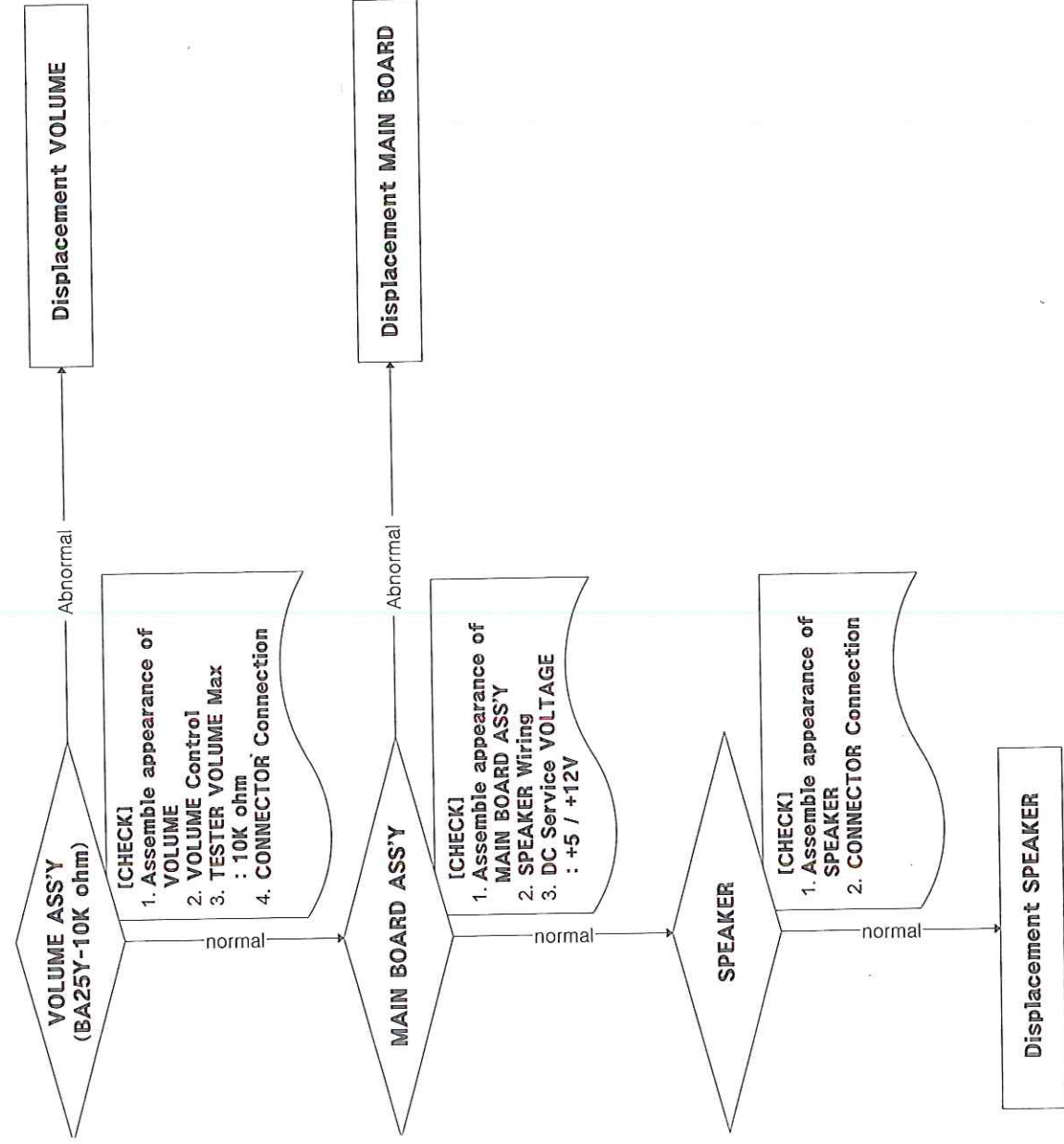

# 6. REPLACEMENT OF CONSUMABLES

## 6-1. REPLACEMENT OF MOTOR

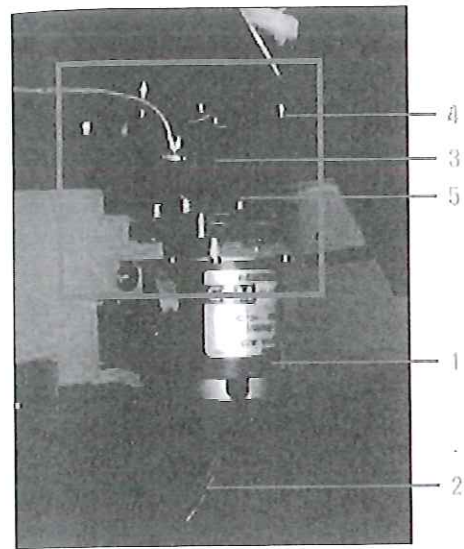

PICTURE A

- (1) Disassemble 2 connector from 1 motor.
- (2) Like Picture A, Loosen 3 M4 bolt (4spot) & 4 M6 bolt (4spots).
- (3) loosen 5 M4 bolt which is connected to Motor, and displace with motor.

NO.	PART NAME	SPEC.	CODE NO.
①	DC MOTOR	KGY-075-12V15W	MZZZ0MOT046

## 6-2. REPLACEMENT OF SENSOR

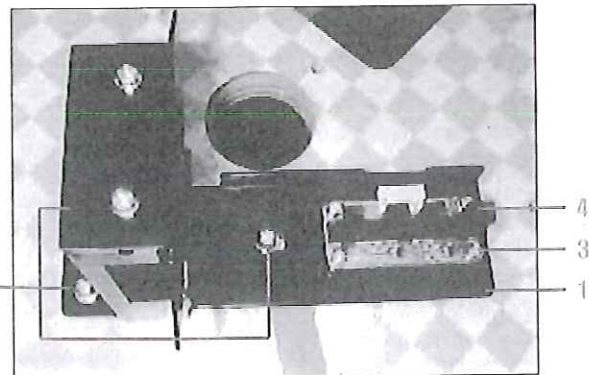

PICTURE A

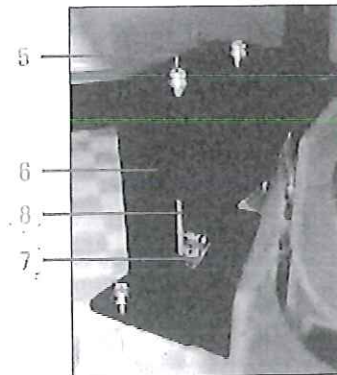

PICTURE B

- (1) Disassemble 1 Wheel sensor bracket by taking out 2 M4 Bolt (3spots), and displace with 4 INT2 PCB ass'y 3 M3 bolt (4spot).
- (2) Loosen 5 M4 bolt, open 6 Wheel sensor guide bracket Dispalce with 8 INT1 PCB ASS'Y 7 M3 bolt (2spots).

NO.	PART NAME	SPEC.	CODE NO.	NO.	PART NAME	SPEC.	CODE NO.
①	WHEEL SENSOR BRACKET	-	MWIT0MEP008	⑥	WHEEL SENSOR GUIDE BRACKET	-	AWIT0MEP010
④	RAMA INT2 PCB ASS'Y	-	AWIW0PCB009	⑧	RAMA INT1 PCB ASS'Y	-	ACIR0PCB011

### 6-3. REPLACEMENT OF MAINBOARD

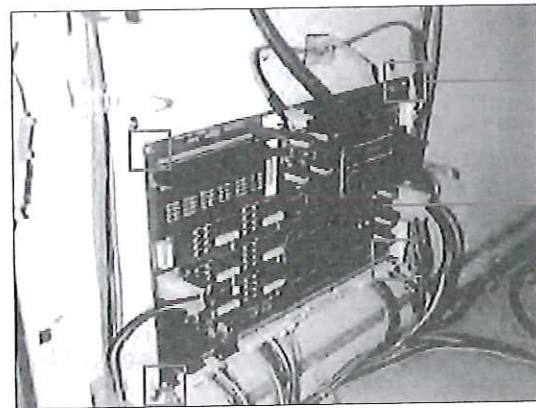

PICTURE A

(1) After taking out connector from Main board  
 2 M4bolt (4spot), displace 1 Main board  
 (Please refer to Picture A)

NO.	PART NAME	SPEC.	CODE NO.
①	MAIN PCB ASS'Y	-	AWITOPCB0

### 6-4. REPLACEMENT OF PCB

(1) BILLBOARD PCB

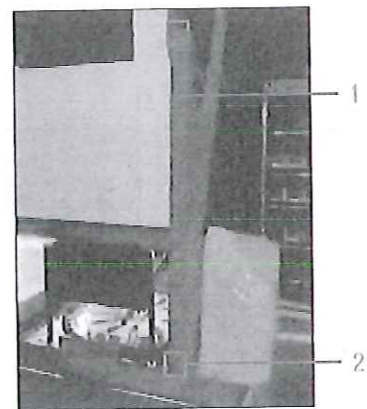

PICTURE A

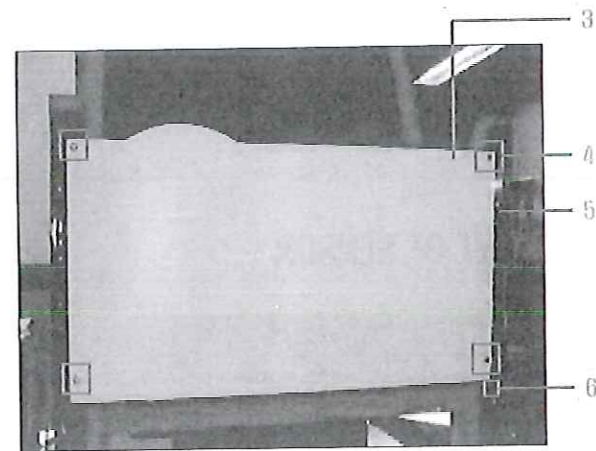

PICTURE B

(1) Taking out 2 M4 bolt (4spots) from 1 "Billboard fixing frame cover".

(2) Displace 5 "Billboard Led PCB Ass'y-L,R" after loose 4 M5 bolt (4spots) from 4 Billbo. Acryl.

NO.	PART NAME	SPEC.	CODE NO.	NO.	PART NAME	SPEC.	CODE NC
①	BILLBOARD FIXING FRAME COVER	-	MWIWOME037	⑤	BILLBOARD LED PCB ASS'Y-L,R	-	MWIWOME027
③	BILLBOARD ACRYL	-	MWIT0ACR005				

(2) FND PCB

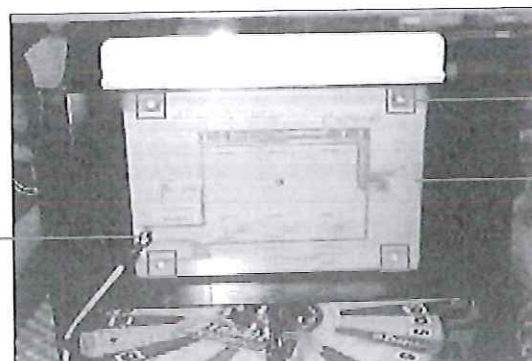

(1) After taking out 1 connector & 3 M3 bolt  
 (4spots), displace 2 FND PCB.

NO.	PART NAME	SPEC.	CODE NC
②	WINNERS FND PCB ASS'Y	-	AWIW0PCB0

## 6-5. REPLACEMENT OF LAMP

### (1) FLUORESCENT LAMP



PICTURE A



PICTURE B

- (1) Turn off power and open 1 front door.
- (2) Displace 3 lamp after disconnecting 2 connector

NO.	PART NAME	SPEC.	CODE NO.
③	FLUORESCENT LAMP	-	MELE0LAM002

### (2) 3 WAVE LAMP

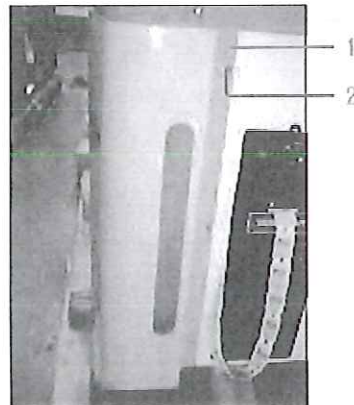

PICTURE A

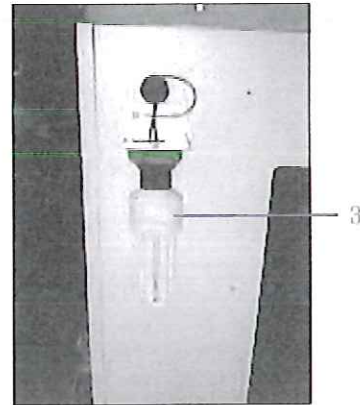

PICTURE B

### (3) GAS DAMPER



PICTURE A

- (1) Turn off power and open 1 Front Frame-L,R
- (2) Please open front door and displace 2 Gas damper after taking out 1 M4 bolt (4spots).

NO.	PART NAME	SPEC.	CODE NO.
①	FRONT FRAME-L,R	-	MWIW0MEP024,054
③	LAMP	3파장(110V 20W)	MELE0LAM005

NO.	PART NAME	SPEC.	CODE NO.
①	GAS DAMPER	KD-302-02(20Kg)	-

# 7. PARTS LIST

## 7-1. ASSEMBLY

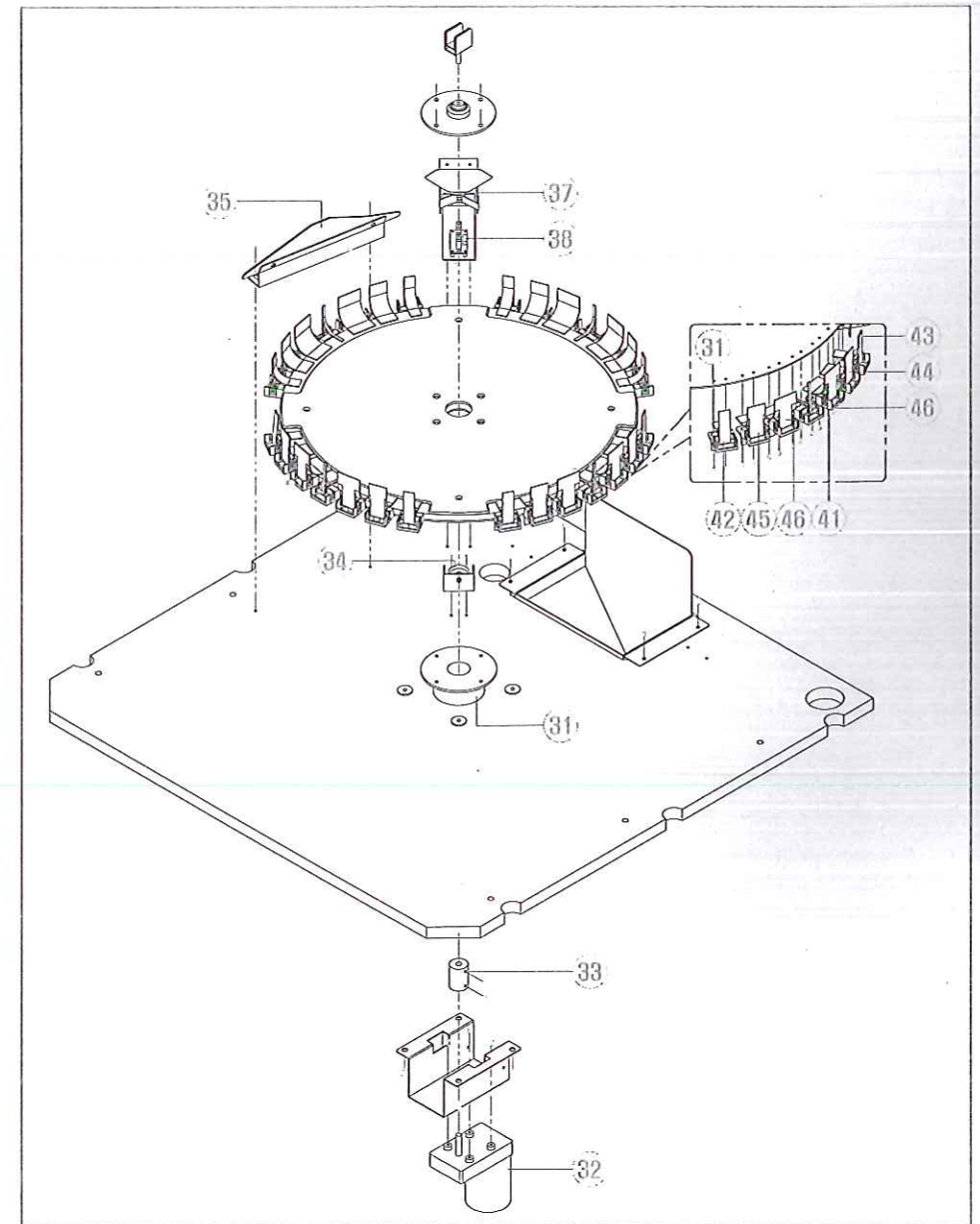
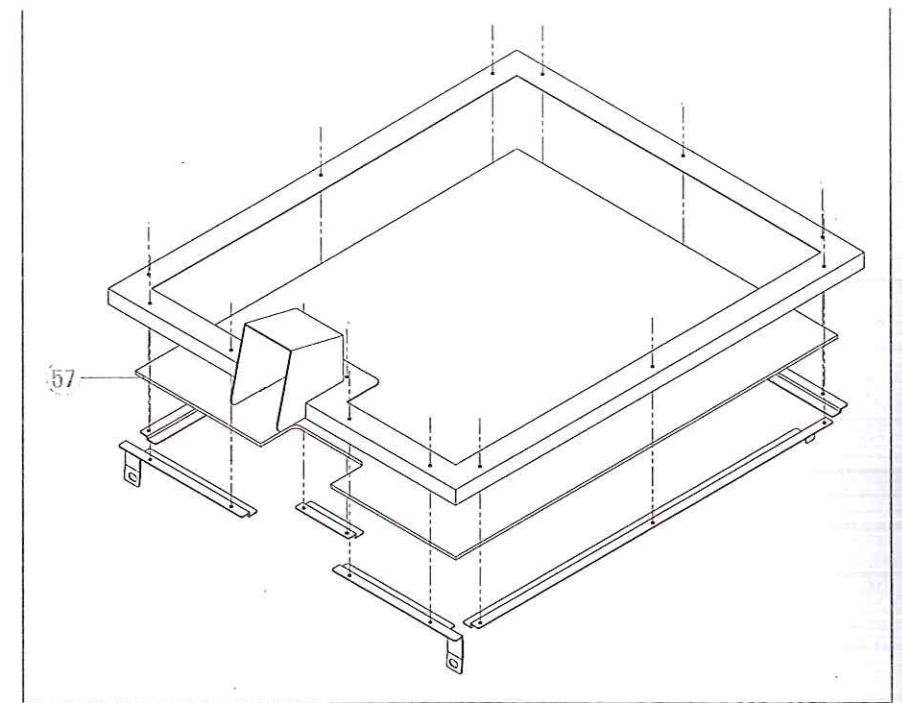
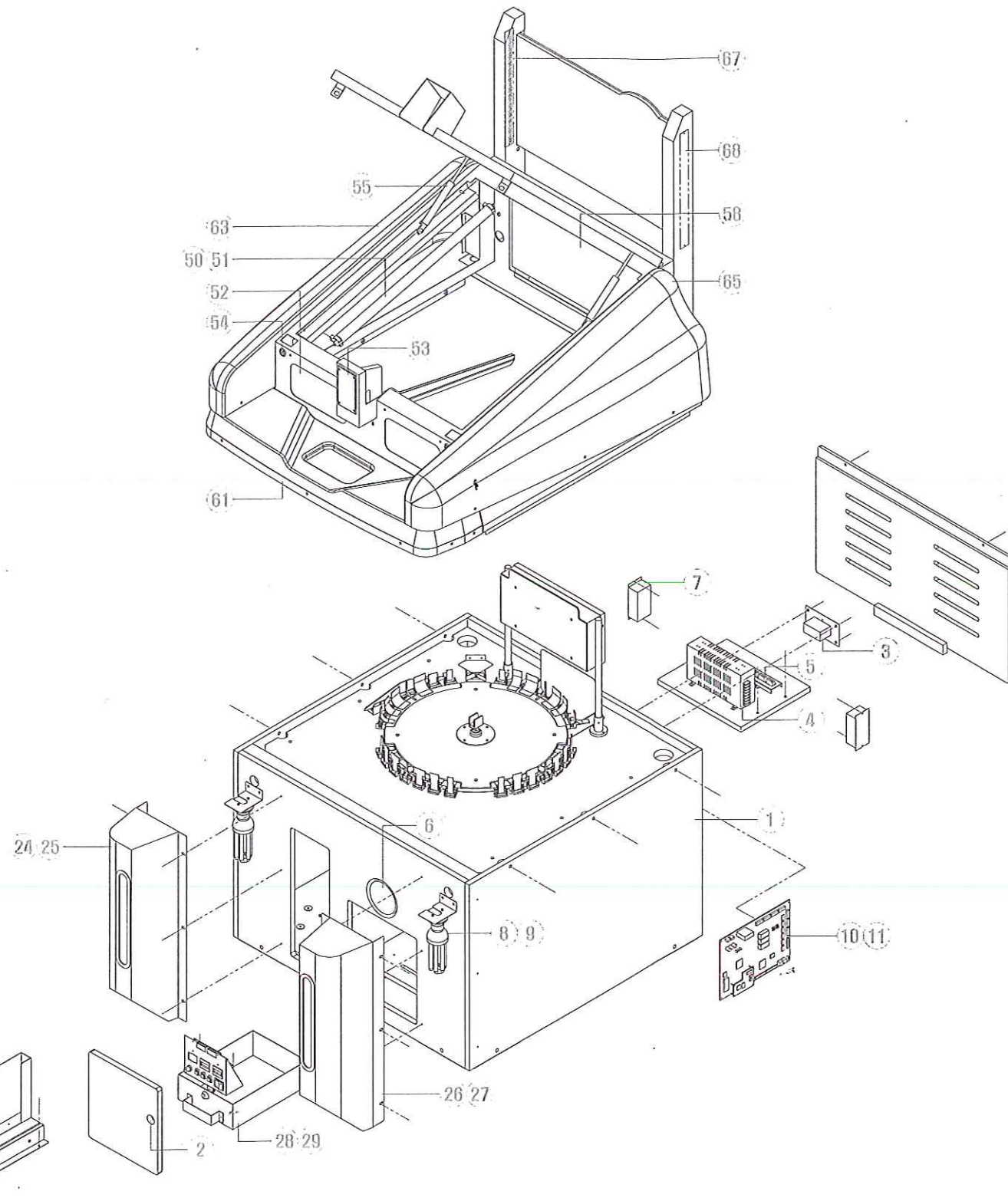
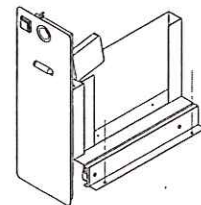
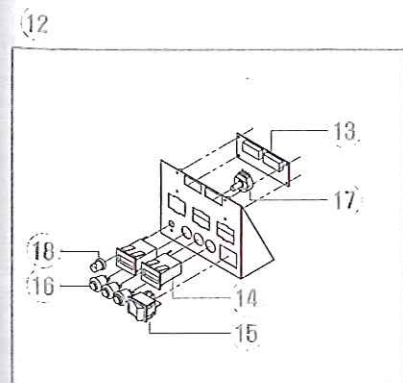
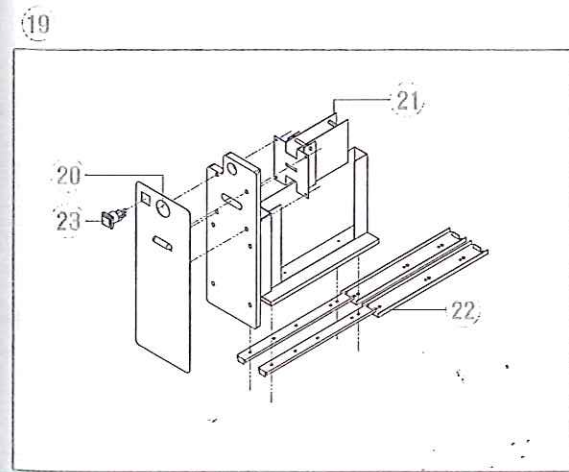
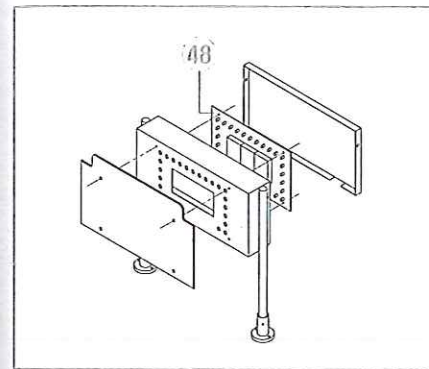

7-2. LIST

NO.	PIC	LEVEL	PART NAME	SPEC.	QTY	CODE NO.
1		1	<b>LOWER CABINET PART</b>			
2	○	2	KEY ASS'Y	CEC C581 680-32	1	MZZZ0KEY041
3	○	2	NOISE FILTER	ES1-F10	1	MELE0NOI006
4	○	2	POWER SMPS	5V-8A,12V-7A	1	MELE0SMP034
5	○	2	AC JOIN PCB ASS'Y	-	1	AZZZ0SPE100
6	○	2	SPEAKER	MID4.5"+TW1/2" 8Ω	1	AZZZ0SPE021
7	○	2	ELECTRONIC BALLAST	110V-1등용	2	MELE0BAL010
8	○	2	AC RECEPTACLE	삼파장 소켓	2	MELE0ARE002
9	○	2	LAMP	3파장(110V 20W)	2	MELE0LAM005
10	○	2	MAIN PCB ASS'Y	-	1	AWIT0PCB001
11		2	CPU PCB ASS'Y	-	1	AWIT0PCB002
12		1	<b>CONTROL PANEL PART</b>			
13	○	2	SETUP FND PCB ASS'Y	WINNER,WON,CIR공용	1	AWIW0PCB008
14	○	2	COUNTER	AMMC-712(7D12V)	2	MZZZ0COU002
15	○	2	ROCKER SWITCH	T-125 4P	1	MELE0SWI004
16	○	2	PUSH BUTTON SWITCH	DS-412R	3	MELE0PUS006
17	○	2	VOLUME	BA25Y-10KΩ	1	MELE0VOL008
18	○	2	VOLUME KNOB	-	1	MELE0VOL006
19		1	<b>TICKET DISPENSER PART</b>			
20		2	KEY ASS'Y	CEC C581 680-32	1	MZZZ0KEY041
21	○	2	TICKET DISPENSER	D TYPE ROHS	1	MZZZ0TID003
22	○	2	GUIDE RAIL	3단-300mm	2	MMUM0000004
23	○	2	BUTTON	AMIPB-26HS-R12D	1	MMUM0BUT002
24		1	<b>FRONT FRAME-L PART</b>			
25	○	2	FRONT LIGHT ACRYL-B	-	1	MWIW0ACR013
26		1	<b>FRONT FRAME-R PART</b>			
27		2	FRONT LIGHT ACRYL-B	-	1	MWIW0ACR013
28		1	<b>COIN BOX PART</b>			
29		2	KEY ASS'Y	CEC C581 680-32	1	MZZZ0KEY041
30		1	<b>GAME PANEL PART</b>			
31		2	WHEEL BEARING BLOCK ASS'Y	-	1	MWIW0ASS002
32	○	2	DC MOTOR	KGY-075-12V15W~	1	MZZZ0MOT046
33		2	COUPLING	-	1	MWIW0PRO023
34	○	2	WHEEL SUPPORT ROLLER ASS'Y	-	1	MFPA0PRO003
35	○	2	TARGET RETURN ACRYL	-	1	MWIT0ACR002

NO.	PIC	LEVEL	PART NAME	SPEC.	QTY	CODE NO.
36		1	<b>WHEEL SENSOR PART</b>			
37	○	2	RAMA INT1 PCB ASS'Y	-	1	ACIR0PCB011
38	○	2	RAMA INT2 PCB ASS'Y	-	1	AWIW0PCB009
39		1	<b>WHEEL PANEL PART</b>			
40	○	2	TARGET BASE	-	28	MFPA0PLA009
41	○	2	TARGET-1.5	1.5mm PINK	4	MFPA0PLA010
42	○	2	TARGET-10	10mm PINK	4	MFPA0PLA012
43	○	2	TARGET-15	15mm PINK	4	MFPA0PLA005
44	○	2	TARGET-20	20mm PINK	4	MFPA0PLA013
45	○	2	TARGET-25	25mm PINK	4	MFPA0PLA006
46	○	2	TARGET-35	35mm PINK	8	MFPA0PLA007
47		1	<b>FND PART</b>			
48	○	2	WINNERS FND PCB ASS'Y	-	1	AWIW0PCB003
49		1	<b>UPPER CABINET PART</b>			
50	○	2	LAMP CLAMP	-	4	MELE0LAM014
51	○	2	FLUORESCENT LAMP	-	2	MELE0LAM002
52	○	2	FRONT WINDOW	-	2	MWIW0GLA001
53	○	2	COIN SELECTOR	HS-03CS+SWITCH	1	MZZZ0COS028
54	○	2	KEY ASS'Y	PUSH TYPE	2	MZZZ0KEY059
55			GAS DAMPER	KD-302-02(20Kg)	2	-
56		1	<b>TOP DOOR PART</b>			
57	○	2	TOP DOOR WINDOW	-	1	MWIW0GLA002
58		1	<b>UPPER REAR DOOR PART</b>			
59	○	2	REAR MIRROR ACRYL	-	1	MWIW0ACR010
60		1	<b>FRONT MOLDING PART</b>			
61	○	2	FRONT MOLDING	-	1	MWIW0ACR016
62		1	<b>SIDE MOLDING-L PART</b>			
63	○	2	SIDE MOLDING L	-	1	MWIW0ACR006
64		1	<b>SIDE MOLDING-R PART</b>			
65	○	2	SIDE MOLDING R	-	1	MWIW0ACR017
66		1	<b>BILLBOARD PART</b>			
67	○	2	BILLBOARD LED PCB-L ASS'Y	-	1	MWIW0PCB027
68	○	2	BILLBOARD LED PCB-R ASS'Y	-	1	MWIW0PCB028

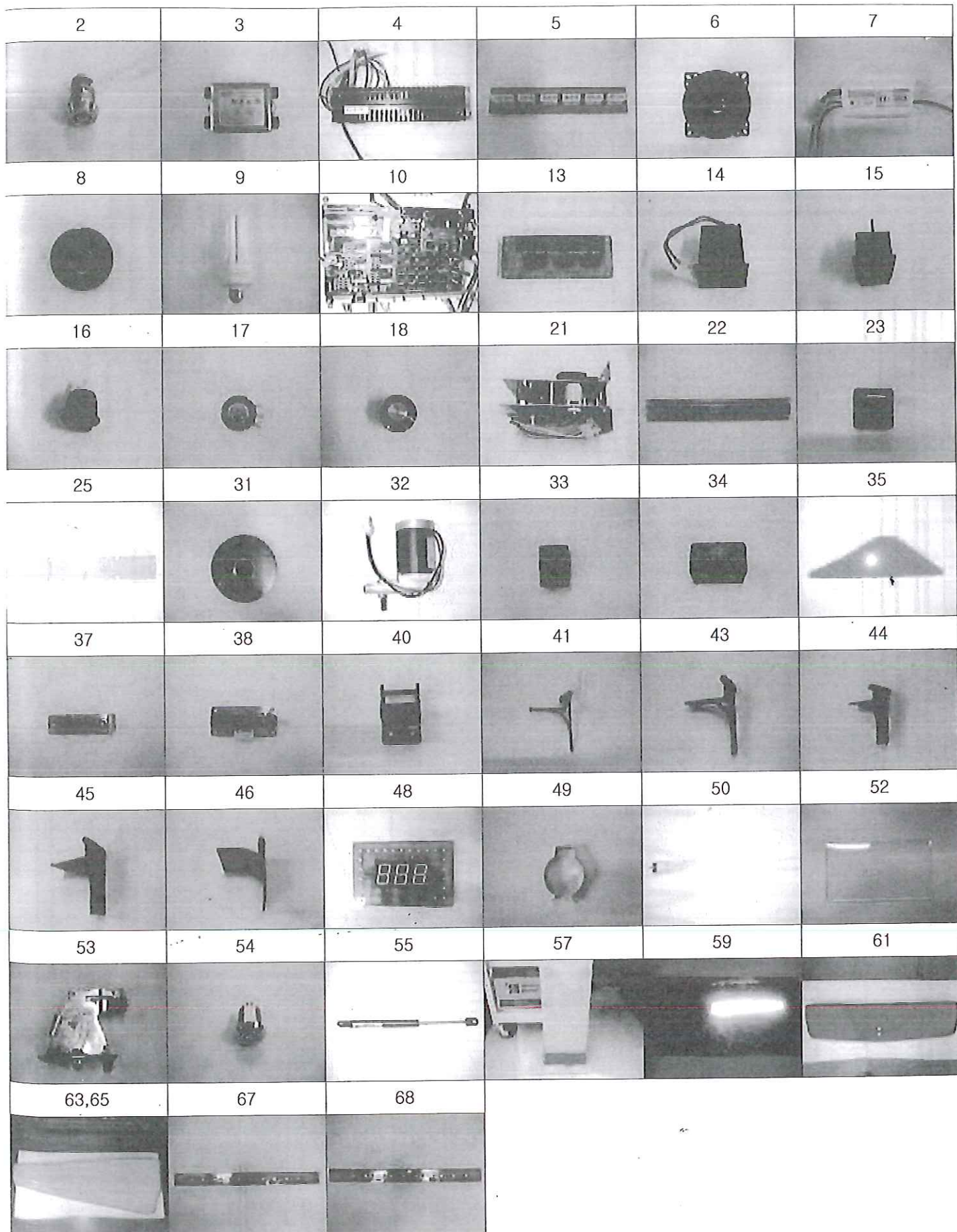

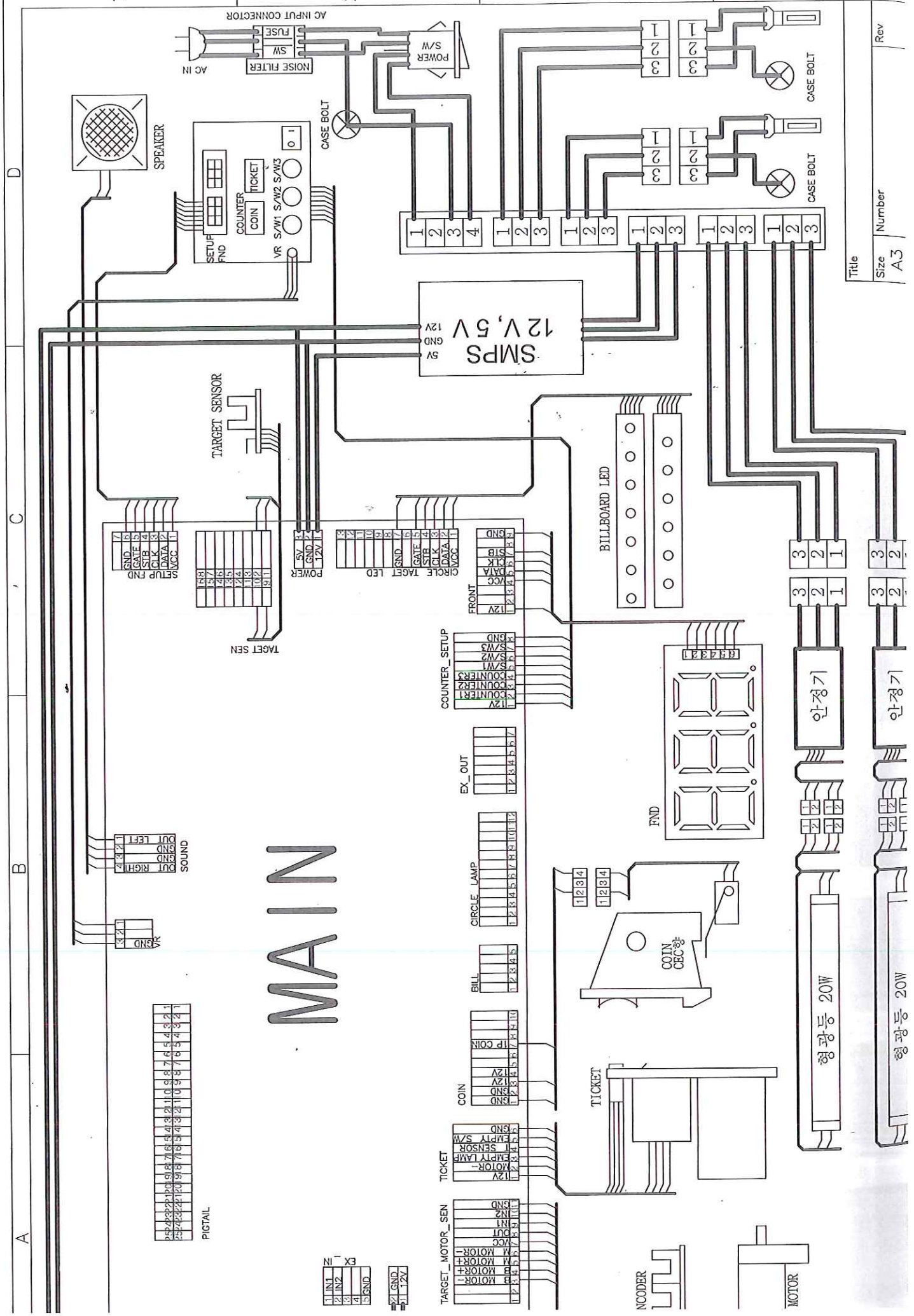

# MAIN

- 1 IN1
- 2 IN2
- 3
- 4
- 5 GND

- 1 GND
- 2 12V

- 1 IN1
- 2 IN2
- 3 IN3
- 4 IN4
- 5 IN5
- 6 IN6
- 7 IN7
- 8 IN8
- 9 IN9
- 10 IN10
- 11 IN11
- 12 IN12
- 13 IN13
- 14 IN14
- 15 IN15
- 16 IN16
- 17 IN17
- 18 IN18
- 19 IN19
- 20 IN20
- 21 IN21
- 22 IN22
- 23 IN23
- 24 IN24

- 1 TICKET MOTOR+
- 2 TICKET MOTOR-
- 3 TICKET MOTOR-
- 4 TICKET MOTOR+
- 5 TICKET MOTOR+
- 6 TICKET MOTOR-
- 7 TICKET MOTOR-
- 8 TICKET MOTOR+
- 9 TICKET MOTOR-
- 10 TICKET MOTOR+
- 11 TICKET MOTOR-
- 12 TICKET MOTOR+
- 13 TICKET MOTOR-
- 14 TICKET MOTOR+
- 15 TICKET MOTOR-
- 16 TICKET MOTOR+
- 17 TICKET MOTOR-
- 18 TICKET MOTOR+
- 19 TICKET MOTOR-
- 20 TICKET MOTOR+
- 21 TICKET MOTOR-
- 22 TICKET MOTOR+
- 23 TICKET MOTOR-
- 24 TICKET MOTOR+

- 1 COIN MOTOR+
- 2 COIN MOTOR-
- 3 COIN MOTOR-
- 4 COIN MOTOR+
- 5 COIN MOTOR+
- 6 COIN MOTOR-
- 7 COIN MOTOR-
- 8 COIN MOTOR+
- 9 COIN MOTOR-
- 10 COIN MOTOR+
- 11 COIN MOTOR-
- 12 COIN MOTOR+
- 13 COIN MOTOR-
- 14 COIN MOTOR+
- 15 COIN MOTOR-
- 16 COIN MOTOR+
- 17 COIN MOTOR-
- 18 COIN MOTOR+
- 19 COIN MOTOR-
- 20 COIN MOTOR+
- 21 COIN MOTOR-
- 22 COIN MOTOR+
- 23 COIN MOTOR-
- 24 COIN MOTOR+

- 1 BILL
- 2 BILL
- 3 BILL
- 4 BILL
- 5 BILL
- 6 BILL
- 7 BILL
- 8 BILL
- 9 BILL
- 10 BILL
- 11 BILL
- 12 BILL
- 13 BILL
- 14 BILL
- 15 BILL
- 16 BILL
- 17 BILL
- 18 BILL
- 19 BILL
- 20 BILL
- 21 BILL
- 22 BILL
- 23 BILL
- 24 BILL

- 1 CIRCLE LAMP
- 2 CIRCLE LAMP
- 3 CIRCLE LAMP
- 4 CIRCLE LAMP
- 5 CIRCLE LAMP
- 6 CIRCLE LAMP
- 7 CIRCLE LAMP
- 8 CIRCLE LAMP
- 9 CIRCLE LAMP
- 10 CIRCLE LAMP
- 11 CIRCLE LAMP
- 12 CIRCLE LAMP
- 13 CIRCLE LAMP
- 14 CIRCLE LAMP
- 15 CIRCLE LAMP
- 16 CIRCLE LAMP
- 17 CIRCLE LAMP
- 18 CIRCLE LAMP
- 19 CIRCLE LAMP
- 20 CIRCLE LAMP
- 21 CIRCLE LAMP
- 22 CIRCLE LAMP
- 23 CIRCLE LAMP
- 24 CIRCLE LAMP

- 1 EX\_OUT
- 2 EX\_OUT
- 3 EX\_OUT
- 4 EX\_OUT
- 5 EX\_OUT
- 6 EX\_OUT
- 7 EX\_OUT
- 8 EX\_OUT
- 9 EX\_OUT
- 10 EX\_OUT
- 11 EX\_OUT
- 12 EX\_OUT
- 13 EX\_OUT
- 14 EX\_OUT
- 15 EX\_OUT
- 16 EX\_OUT
- 17 EX\_OUT
- 18 EX\_OUT
- 19 EX\_OUT
- 20 EX\_OUT
- 21 EX\_OUT
- 22 EX\_OUT
- 23 EX\_OUT
- 24 EX\_OUT

- 1 COUNTER\_SETUP
- 2 COUNTER\_SETUP
- 3 COUNTER\_SETUP
- 4 COUNTER\_SETUP
- 5 COUNTER\_SETUP
- 6 COUNTER\_SETUP
- 7 COUNTER\_SETUP
- 8 COUNTER\_SETUP
- 9 COUNTER\_SETUP
- 10 COUNTER\_SETUP
- 11 COUNTER\_SETUP
- 12 COUNTER\_SETUP
- 13 COUNTER\_SETUP
- 14 COUNTER\_SETUP
- 15 COUNTER\_SETUP
- 16 COUNTER\_SETUP
- 17 COUNTER\_SETUP
- 18 COUNTER\_SETUP
- 19 COUNTER\_SETUP
- 20 COUNTER\_SETUP
- 21 COUNTER\_SETUP
- 22 COUNTER\_SETUP
- 23 COUNTER\_SETUP
- 24 COUNTER\_SETUP

- 1 FRONT
- 2 FRONT
- 3 FRONT
- 4 FRONT
- 5 FRONT
- 6 FRONT
- 7 FRONT
- 8 FRONT
- 9 FRONT
- 10 FRONT
- 11 FRONT
- 12 FRONT
- 13 FRONT
- 14 FRONT
- 15 FRONT
- 16 FRONT
- 17 FRONT
- 18 FRONT
- 19 FRONT
- 20 FRONT
- 21 FRONT
- 22 FRONT
- 23 FRONT
- 24 FRONT

- 1 GND
- 2 GND
- 3 GND
- 4 GND
- 5 GND
- 6 GND
- 7 GND
- 8 GND
- 9 GND
- 10 GND
- 11 GND
- 12 GND
- 13 GND
- 14 GND
- 15 GND
- 16 GND
- 17 GND
- 18 GND
- 19 GND
- 20 GND
- 21 GND
- 22 GND
- 23 GND
- 24 GND

- 1 TAGET\_LED
- 2 TAGET\_LED
- 3 TAGET\_LED
- 4 TAGET\_LED
- 5 TAGET\_LED
- 6 TAGET\_LED
- 7 TAGET\_LED
- 8 TAGET\_LED
- 9 TAGET\_LED
- 10 TAGET\_LED
- 11 TAGET\_LED
- 12 TAGET\_LED
- 13 TAGET\_LED
- 14 TAGET\_LED
- 15 TAGET\_LED
- 16 TAGET\_LED
- 17 TAGET\_LED
- 18 TAGET\_LED
- 19 TAGET\_LED
- 20 TAGET\_LED
- 21 TAGET\_LED
- 22 TAGET\_LED
- 23 TAGET\_LED
- 24 TAGET\_LED

- 1 5V
- 2 5V
- 3 5V
- 4 5V
- 5 5V
- 6 5V
- 7 5V
- 8 5V
- 9 5V
- 10 5V
- 11 5V
- 12 5V
- 13 5V
- 14 5V
- 15 5V
- 16 5V
- 17 5V
- 18 5V
- 19 5V
- 20 5V
- 21 5V
- 22 5V
- 23 5V
- 24 5V

- 1 12V
- 2 12V
- 3 12V
- 4 12V
- 5 12V
- 6 12V
- 7 12V
- 8 12V
- 9 12V
- 10 12V
- 11 12V
- 12 12V
- 13 12V
- 14 12V
- 15 12V
- 16 12V
- 17 12V
- 18 12V
- 19 12V
- 20 12V
- 21 12V
- 22 12V
- 23 12V
- 24 12V

- 1 GND
- 2 GND
- 3 GND
- 4 GND
- 5 GND
- 6 GND
- 7 GND
- 8 GND
- 9 GND
- 10 GND
- 11 GND
- 12 GND
- 13 GND
- 14 GND
- 15 GND
- 16 GND
- 17 GND
- 18 GND
- 19 GND
- 20 GND
- 21 GND
- 22 GND
- 23 GND
- 24 GND

- 1 1
- 2 2
- 3 3
- 4 4
- 5 1
- 6 2
- 7 3
- 8 1
- 9 2
- 10 3
- 11 1
- 12 2
- 13 3
- 14 1
- 15 2
- 16 3
- 17 1
- 18 2
- 19 3
- 20 1
- 21 2
- 22 3
- 23 1
- 24 2
- 25 3

- 1 1
- 2 2
- 3 3
- 4 1
- 5 2
- 6 3
- 7 1
- 8 2
- 9 3
- 10 1
- 11 2
- 12 3
- 13 1
- 14 2
- 15 3
- 16 1
- 17 2
- 18 3
- 19 1
- 20 2
- 21 3
- 22 1
- 23 2
- 24 3

- 1 1
- 2 2
- 3 3
- 4 1
- 5 2
- 6 3
- 7 1
- 8 2
- 9 3
- 10 1
- 11 2
- 12 3
- 13 1
- 14 2
- 15 3
- 16 1
- 17 2
- 18 3
- 19 1
- 20 2
- 21 3
- 22 1
- 23 2
- 24 3

Title \_\_\_\_\_  
 Size A3  
 Number \_\_\_\_\_  
 Rev \_\_\_\_\_